



DECEMBER 2018

# +RIBRAFT® X-POD®

STRUCTURAL  
DESIGNERS GUIDE



1	Scope	3
2	Description of the System	3
1	DPM	4
2.1	Concrete	4
2.2	Pods	4
2.3	Mesh	6
2.4	Steel	6
2.5	DPM	7
2.6	Optional Gravel raft	7
2.7	Firth HotEdge®	7
2.8	Drawings	8
3	Typical Uses	8
4	Design of the system	8
4.1	Design case 1 - Design to AS/NZS1170 for ground bearing	8
4.2	Design Case 2 - Design for Liquefaction sites	10
4.3	Design case 3 - Design for expansive soil site	11
5	R values	12
6	Plumbing	13
6.1	Below Slab Plumbing Installation Methodology	13
6.2	In Floor Plumbing Installation methodology	14
6.3	Recesses for showers	16
7	Finish floor level above ground	17
8	Design Documentation	17
9	References	17



## 1 SCOPE

This design guide has been developed for the exclusive use of CPEng designers who are experienced in the design of residential concrete foundation systems. Only Chartered Professional Engineers with appropriate experience, or persons working under their supervision, shall rely on the information provided in this document.

The system requires specific design and this document provides guidance for suitably qualified persons to design RibRaft® X-Pod® foundation systems for sites which are either:

- Not prone to liquefaction
- Potential for liquefaction and categorised as TC2 using the MBIE guideline<sup>(3)</sup>
- Sites containing expansive soils

Use of the Manual entails a commitment by the Designer to specify that the concrete shall be supplied by Firth Industries. The X-Pod®s are only available from Firth Industries and shall only be supplied to a project with confirmation of an order for Firth concrete.

## 2 DESCRIPTION OF THE SYSTEM

The Firth RibRaft® X-Pod® flooring system comprises of:

- Firth concrete mix IP2019X or IP2519X, refer section 2.1
- A matrix of RibRaft® X-Pod® formers to create a total floor thickness of 300mm with ribs at 750 or 1500mm centres and 85mm minimum topping above the RibRaft® X-Pod®s, refer section 2.2
- Mesh in the topping, refer section 2.3
- Reinforcement typically in the form of DH10s or larger diameter in the ribs, perimeter and load bearing beams, section 2.4
- DMP providing a vapour barrier between ground and flooring system, section 2.5
- Dependent upon soil conditions the flooring system may sit on a specifically designed compacted gravel raft, section 2.6
- The system is compatible with Firth HotEdge® should slab edge insulation be specified, section 2.7

FIGURE 1 - THE RIBRAFT® X-POD® SYSTEM

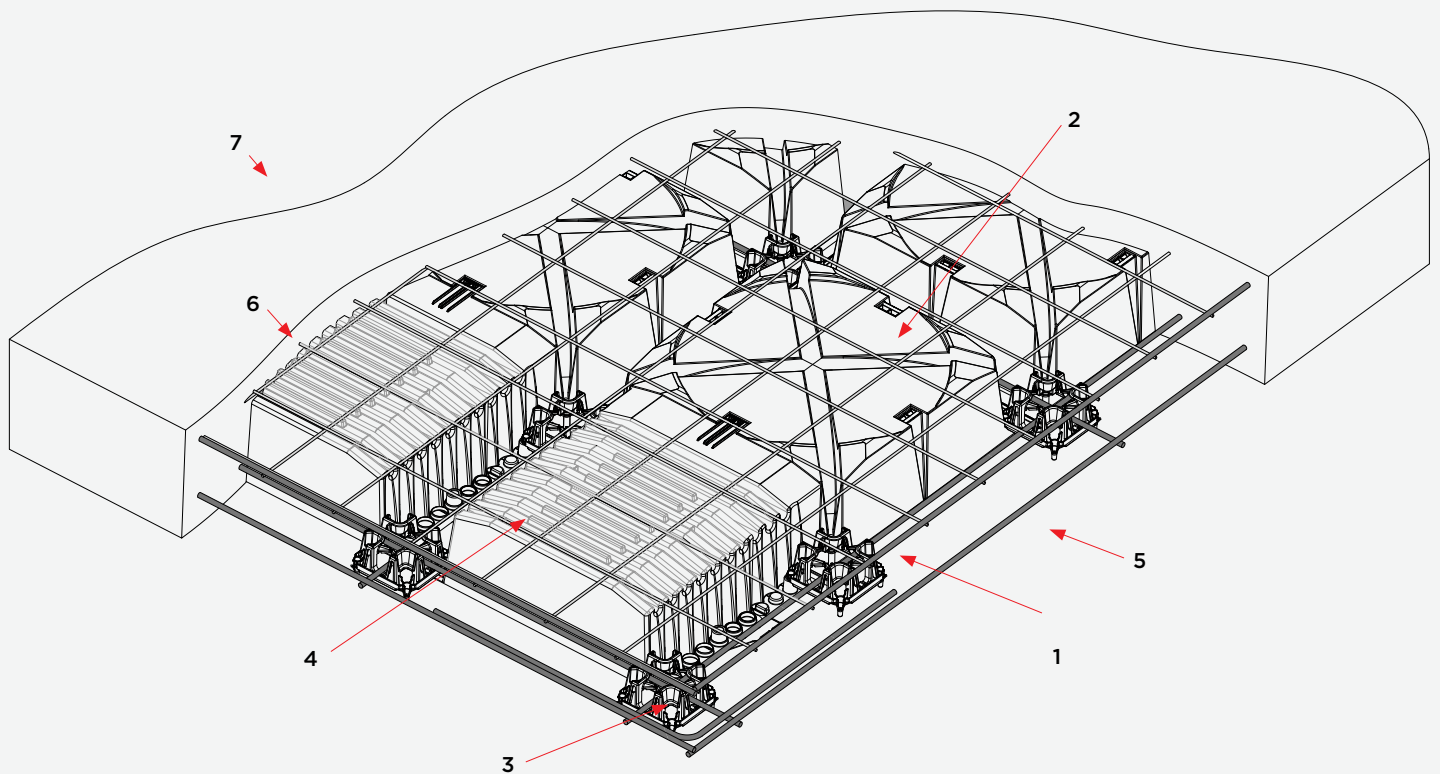

- |   |  |
|---|--|
| 1 | DPM  |
| 2 | RibRaft® X-Pod® (215/750 or 215/1500)                  |
| 3 | RibRaft® Keystone 8/16                                 |
| 4 | RibRaft® ADJ Pod (215/150.400 and ADJ Pod 215/450.700) |

- |   |  |
|---|--|
| 5 | Steel reinforcing (bars)                     |
| 6 | Steel reinforcing (mesh)                     |
| 7 | Firth Concrete (mix code IP2019X or IP2519X) |

## 2.1 CONCRETE

RibRaft® X-Pod® Foundation systems require a specific Firth designed concrete mix. Choose one of the following:

**1 X-Pod® Mix IP2019X** - a 20MPa 120mm slump mix available as a pump mix suitable for 100mm pump lines available in either a 13mm or more usually a 19mm nominal aggregate size, or as a structural (non-pump) mix

**2 X-Pod® Mix IP2519X** - a 25MPa 120mm slump mix available as a pump mix suitable for 100mm pump lines available in either a 13mm or more usually a 19mm nominal aggregate size, or as a structural (non-pump) mix. This mix shall be specified for buildings constructed in the 'sea spray zone' (i.e. within 500m of the sea including harbours, within 100m of tidal estuaries or inlets, on offshore islands and elsewhere as defined as exposure zone D in 4.2.3.3 of NZS3604).

The X-Pod® system is available across most of NZ, where there is a Firth Concrete plant available to supply the X-Pod® special mix concrete. However in some parts of the county, X-Pod® isn't available including Kaitaia, Wairarapa, Kaikoura, Motueka and Golden Bay, where there is no Firth Plant or a Firth Plant is too far away to make the supply of X-Pod® concrete feasible. In these cases, please talk to your local Firth rep for more information and to discuss a suitable alternative foundation design.

## 2.2 PODS

The Firth RibRaft® X-Pod® flooring system comprises of 4 pod options which are linked using the X-Pod® Keystone clip to create an efficient and strong flooring system. The pod options are:

- **RibRaft® X-Pod® 215/750.** These units, when laid out and linked with the X-Pod® keystone create a grid with 100mm ribs at 750 centres. The height of the pods are 215mm which when combined with 85mm of concrete topping give a total floor thickness of 300mm. *See Figure 2.*
- **RibRaft® X-Pod® 215/1500.** These units, when laid and linked with the X-Pod® keystone create a grid with 100mm ribs at 1500 centres. The units are designed to form a cross shaped concrete column in the centre of the 1500mm rib grid. The height of the pods are 215mm which when combined with 85mm of concrete topping give a total floor thickness of 300mm. *See Figure 3.*
- **RibRaft® two part adjustment pod. ADJ Pod (215/150.400 and ADJ Pod 215/450.700).** These units can be used when the required spacing between beams and ribs is less than 750mm. The 215/150.400 unit contains a top mounted clip which allows it to be securely connected to other X-Pod® units. Without modification the unit fills a 400mm void. With cutting and overlapping the unit can fill voids of between 150 and 400mm. When combined with the ADJ 215/450.700 unit, voids of between 450 to 700mm can be filled. *Figure 4 illustrates the units.*

FIGURE 2 - TYPICAL RIBS LAYOUT OBTAINED WITH RIBRAFT® X-POD®S 215/750

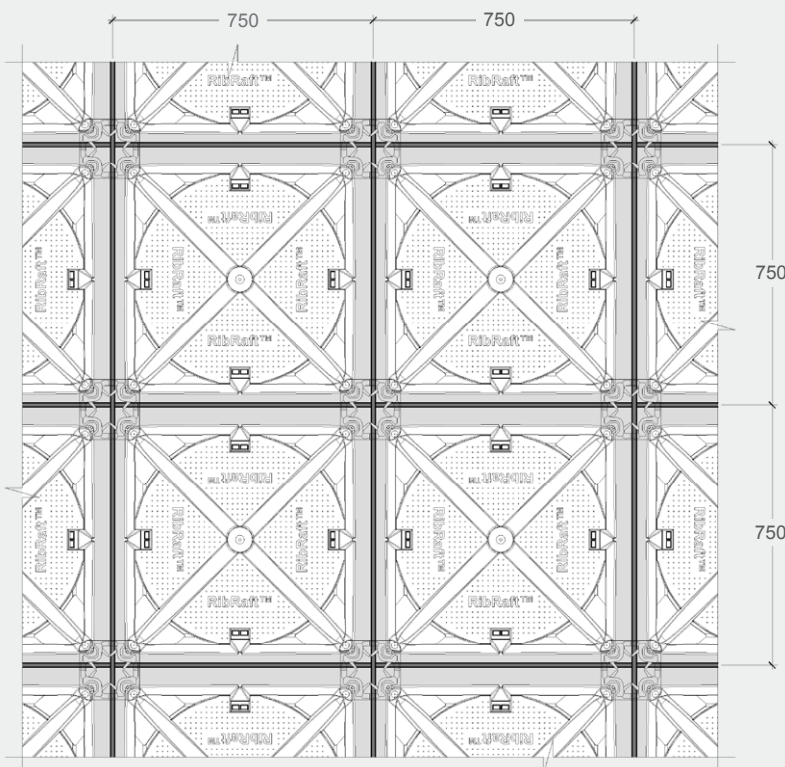

Illustration: © Cresco.co.nz



FIGURE 3 - TYPICAL RIBS LAYOUT OBTAINED WITH RIBRAFT® X-POD®S 215/1500

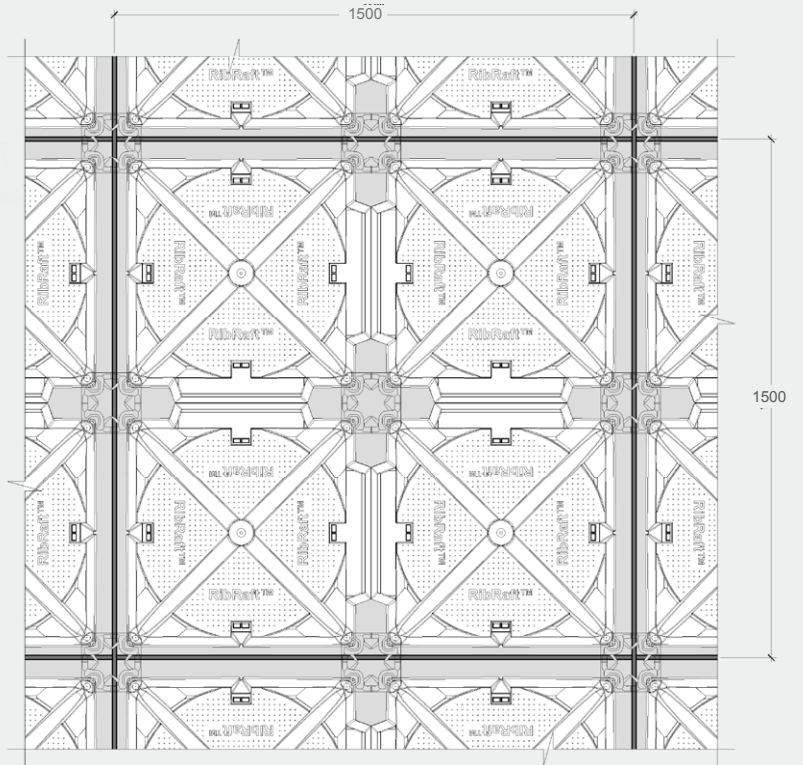
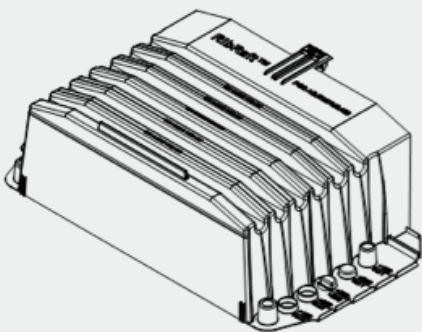
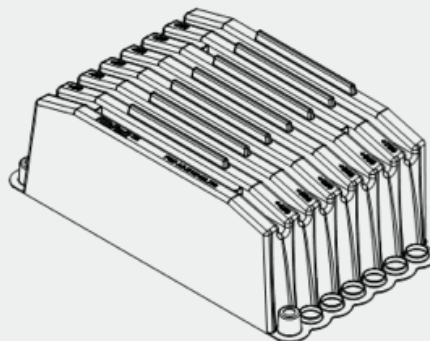

Illustration: © Cresco.co.nz

FIGURE 4 - RIBRAFT® X-POD® TWO PART ADJUSTMENT PODS



RibRaft® X-Pod® ADJ 215/150.400



RibRaft® X-Pod® ADJ 215/450.700

Illustrations: © Cresco.co.nz

Firth RibRaft® X-Pod®s are placed directly on levelled ground and are arranged in such a way as to form a reinforced concrete floor slab with a grid of reinforced concrete ribs and edge beams when concrete is placed onto them. The RibRaft® ADJ Series X-Pod®s may be used to suit specific architecture layout and also to accommodate services.

*Figure 5* shows how the various X-Pod® components might be utilised on a complex floor arrangement where liquefaction or expansive soils are not a consideration.

FIGURE 5 - EXAMPLE OF HOW THE VARIOUS X-POD® COMPONENTS CAN BE UTILISED ON A COMPLEX SHAPED FLOOR

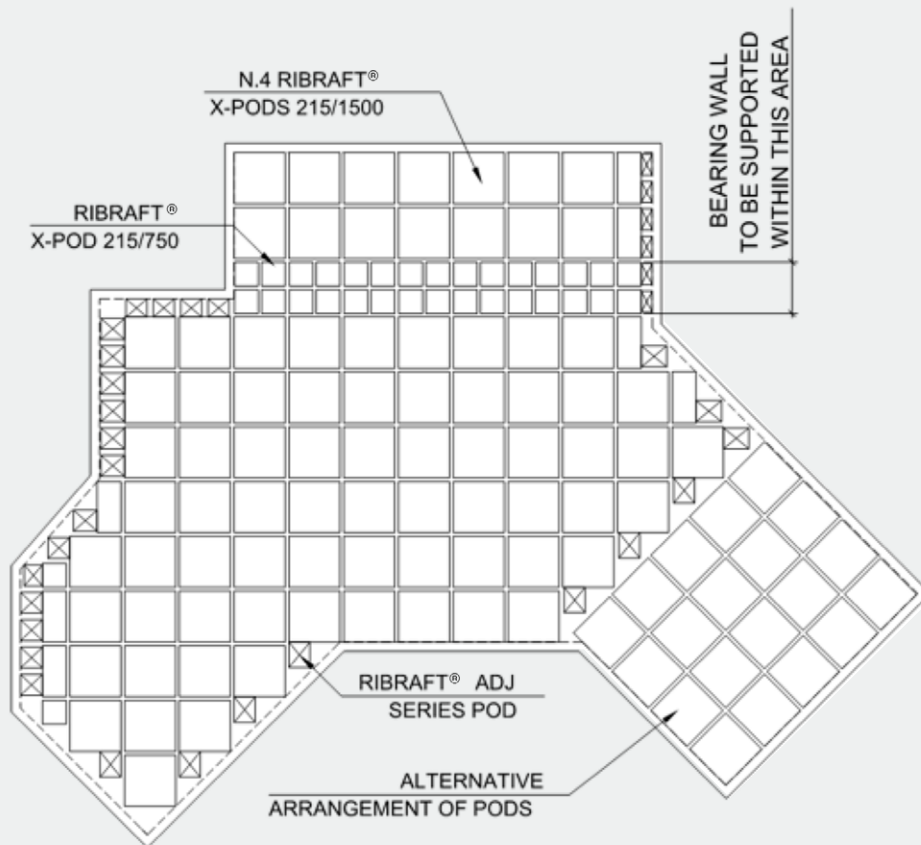

### 2.3 MESH

Mesh shall be Grade 500 and comply with AS/NZS 4671:2001. Typically the mesh will be 665 mesh (Class L) or SE62 ductile mesh (Class E). The design engineer shall specify the required mesh.

Class L mesh can be used when the sole purpose is limitation of crack widths and the ground conditions are defined as good in terms of NZS3604. The Class E reinforcing bars in the ribs and beams provides adequate ductility of the system which allow the use of Class L mesh.

Class E shall be used when the mesh performs a structural function such as a slab on ground prone to liquefaction or expansive soils.

Mesh shall be lapped in accordance with NZS3101.

Two options are available for supporting the mesh:

- 1 The mesh can be supported on mesh chairs to achieve cover to the top surface of 35mm. This methodology minimises the cover and therefore enhances the crack width limiting ability of the mesh. It also maximises the internal leverarm and therefore the bending strength when subjected to moments causing the mesh to go into tension.

- 2 The mesh can alternatively be laid on upstands provided in the corners of the pods. The 15mm upstands on the pods mean that cover from the concrete surface to the mesh (SE62) is 58mm and slightly less at mesh overlaps. This solution provides greater economy and stability of the mesh.

### 2.4 STEEL

The reinforcing bars in the ribs and edge beams shall conform to AS/NZS 4671:2001 Grade 500, Class E "Steel Reinforcing Materials". The volume of reinforcement shall be determined by the designer.

For sites not prone to liquefaction or expansion, the ribs (100mm wide) are normally reinforced with a single DH10 and the perimeter edge beam (minimum 250mm wide) with 2DH10s at the bottom and one DH10 in the plane of the mesh. This volume of reinforcement satisfies the minimum flexural reinforcement requirements for NZS3101. The Keystones hold the reinforcement in position without the need for tying. The Keystone can accommodate up to two DH16 bars at a lap position.

## 2.5 DPM

The damp proof membrane (DPM) material shall be polyethylene sheet in accordance with NZS 3604:2011. The DPM shall be laid over the entire building platform directly on top of a sand blinding layer, extending to the outside of the edge beam. The joints shall be lapped not less than 50mm and sealed with pressure sensitive tape not less than 50mm wide. All penetrations of the DPM by plumbing and services or punctures during construction shall also be sealed with pressure sensitive tape. The DPM may extend beyond the edge of the slab i.e. underneath the formwork, or may be folded and stapled up the inside of the formwork. The minimum requirement is that the DPM extends to the outside of the edge beam. It is very important that the DPM is not bunched up at the formwork.

Where enhanced thermal performance is required, ThermoX DPM can be used as the DPM.

## 2.6 OPTIONAL GRAVEL RAFT

The RibRaft® X-Pod® flooring system can sit directly on the soil, where ground bearing conditions permit although a sand blinding layer may be required to provide puncture resistance to the DPM. Where ground conditions are soft, a compacted gravel raft can be provided to reduce the bearing pressures in the natural ground to acceptable levels. For strip foundations an assumed load spread of 1 vertically to 0.5 horizontally approximates the pressure spread using Boussinesq analysis for an elastic half space and can be used to determine the required thickness of gravel.

An evaluation of whether expression of liquefaction ejecta is likely at the surface should be conducted for systems sited in TC2 liquefaction zones (refer MBE guidelines <sup>(3)</sup> for TC2 classification). The aim of this being to minimise the potential for liquefaction ejected entering the voids of the X-Pod® system. Isihara<sup>(11)</sup> found that where the depth to the water table is 3m the presence of sand boils are rare. For sites such as these, no specific mechanism for reducing the ingress of liquefaction sand into the X-Pod® voids would be required.

Where the water table is closer than 3m to the surface, Van Ballegooy<sup>(12)</sup> suggest that the Liquefaction Severity Number (LSN) provides a good indication of the expression of liquefaction ejecta at the surface. Specific geotechnical advice should be provided, however it is suggested that based on the LSN in the Ultimate Limit State:

<b>LSN 0-20</b>	Little or no expression of liquefaction is expected, therefore there is no need to consider methods of preventing ejecta entering the voids.
<b>LSN 20-40</b>	Moderate expression of liquefaction expected, consider providing a thin gravel raft (150mm) overlying a geofabric below the X-Pod® flooring system.
<b>LSN 40+</b>	Widespread expression of liquefaction expected, consider using a specifically designed geofabric and geogrid reinforced gravel layer below the X-Pod® system.

## 2.7 FIRTH HOTEDGE®

Where additional thermal efficiency is required, Firth HotEdge® can be incorporated into the design. Refer to the Firth web page for more information.



## 2.8 DRAWINGS

Typical autocad drawings showing a range of details are available for customisation by the designer. These drawings are provided on the basis that the designer will review and take responsibility for their accuracy. Requests for drawings should be made via **0800 FIRTH 1 (0800 347 841)**.

### 3 TYPICAL USES

**Table 1** provides RibRaft® X-Pod® systems which are used in various ground scenarios. The table is provided as guidance and the designer may choose which ever option works best for the design.

**TABLE 1 - TYPICAL RIBRAFT® X-POD® SYSTEMS**

	DESIGN SCENARIO	POSSIBLE RIBRAFT® X-POD® SOLUTION
1	Good ground conditions as defined in NZS3604	X-Pod® 215/1500 pods with a minimum 250mm wide perimeter beams sitting directly on ground after removal of organic topsoil. When using brick veneer, a minimum 300mm wide perimeter beams are used to accommodate the rebate for the bricks
2	As 1, but with soil bearing capacity between 150- 300 kPa	As 1, but check bearing pressure below foundation beams. If required provide gravel raft to minimise bearing pressures in soil.
3	Foundations on sites prone to liquefaction and categorised as TC2 <sup>(a)</sup>	X-Pod® 215/750, designed as outlined in this document
4	Foundations on expansive clays, Class M or H <sup>(b)</sup>	X-Pod® 215/750, designed as outlined in this document

<sup>(a)</sup> The definition of TC2 is as provided in the MBIE Guidance "Repairing and rebuilding houses affected by the Canterbury earthquakes"<sup>(3)</sup>

<sup>(b)</sup> As defined in AS2870<sup>(4)</sup>

### 4 DESIGN OF THE SYSTEM

The following outlines the design approach for the three potential design scenarios:

- 1 Design for ground bearing pressure
- 2 Design for liquefaction sites (TC2)
- 3 Design for expansive soil sites

#### 4.1 DESIGN CASE 1 - DESIGN TO AS/NZS1170 FOR GROUND BEARING

The ground conditions shall be established by a geotechnical investigation compliant with local Territorial Authority requirements and NZS3604.

The likely bearing pressures under perimeter foundation beams, and load bearing beams, shall be established.

Design shall establish that the capacity of the ground exceeds the demands from the foundation system, using an approach compliant with the NZ Building Code.

Reinforcement shall be provides to accommodate the demands on the structural elements.

Typical solutions are provided in **Table 1**.

The system has been designed to ensure that an 85mm concrete topping can support a 13kN point live load over an area of 300mm x300mm. This being AS/NZS1170 requirement for a residential garage. The 85mm slab is also capable of supporting a 10kN point load from a single stud supported on a 90mm wide bottom plate. Note most timber roof truss manufactures identify all loads greater than 10kN.

Both X-Pod® systems (215/750 and 215/1500) act as a grillage when supporting point loads. Finite element analysis was utilised to evaluate the situation where a 13kN point load (including 1.5 load factor) was located above the central cruciform support of the 215/1500 system. Analysis revealed that considerable load transfer occurred through the 85mm slab meaning that only approximately 10% of the load was resisted by direct bearing under the point load the remainder being shed to the supporting grillage of beams. The analysis demonstrated the ability of the system to support 13kN point loads in any location.

The weight of the floor above the pods can be estimated by calculating the overall volume including the pods (typically 750x750x300) and deducting the volume of the X-Pod®s provided in **Table 2**.



TABLE 2 - VOLUME OF RIBRAFT® X-POD®S

TYPE OF X-POD®	VOLUME (LITRES)	LOADING FOR TYPICAL 300MM THICK FLOOR
215/750	83	3.7kPa
215/1500	91	3.3kPa

The bearing capacity of a grillage of closely spaced foundations is a complex analytical problem as the pressure bulbs from adjacent foundation can interact providing confinement and providing a capacity which is greater than the sum of the individual foundations <sup>(1)</sup>. Additionally research has shown <sup>(2)</sup> that the bearing capacity of a cruciform foundation is similar but greater than a square foundation of a similar area. Both of these effects can mean that the bearing capacity of the grillage can be considerably greater than would normally be assumed for a 100mm wide foundation strip.

Refined analysis considering the grillage effect can result in foundation systems with negligible need to place footings under load bearing walls. However typically the design effort exceeds the value of any additional concrete used so conservative bearing pressure assumptions based upon strip foundation still produce cost effective solutions.

FIGURE 6 - GRILLAGE EFFECT OF RIBRAFT® X-POD® INTERNAL RIBS

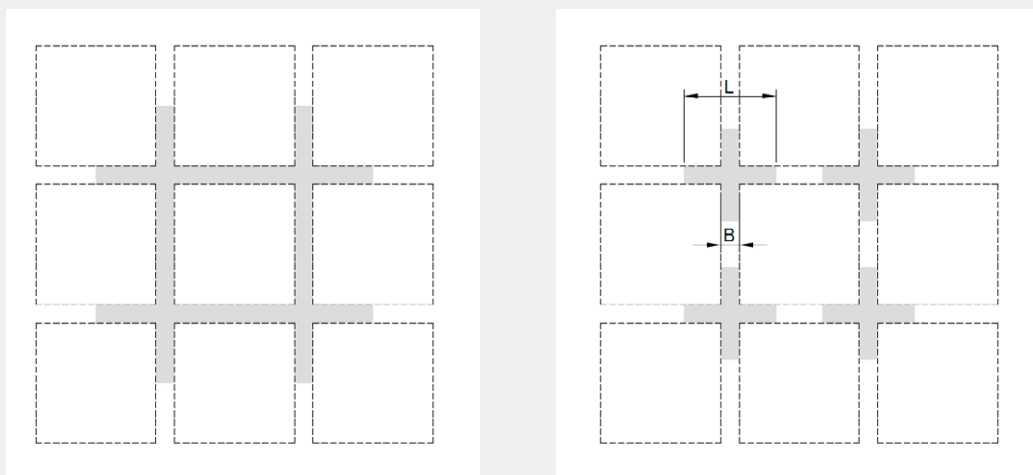

Typical details of the edge beam are provided in *Figure 7*. Reinforcement is determined by the design engineer but is typically 2xDH10s in the bottom of the perimeter beam with 1 DH10 in the top.

FIGURE 7 - TYPICAL DETAILS FOR FLOORS NOT SUBJECTED TO LIQUEFACTION OF EXPANSIVE SOILS

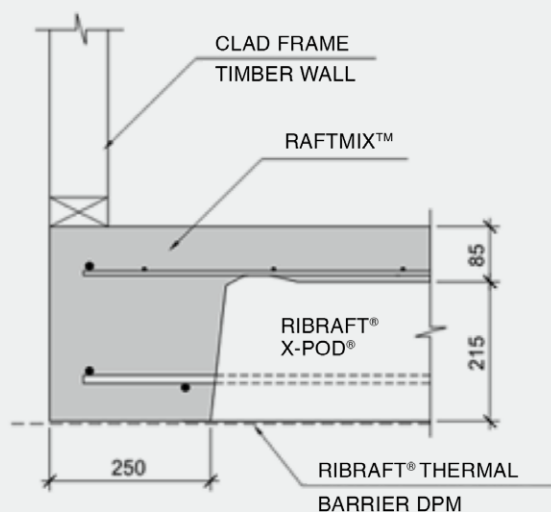
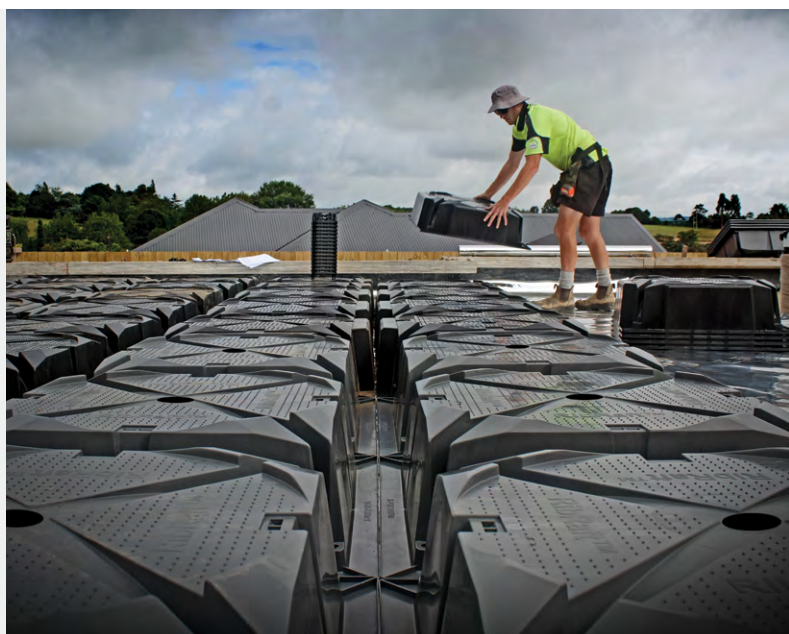

Illustration: © Cresco.co.nz



#### 4.2 DESIGN CASE 2 - DESIGN FOR LIQUEFACTION SITES

The RibRaft® X-Pod® 215/750 pods are recommended for use in sites prone to liquefaction.

Where it has been established that the expected settlement during a SLS or ULS event exceeds the settlement limits for TC1 but are less than those for TC2, then the flooring system shall be designed as outlined in this section. The settlement index criteria from the MBIE technical guidance document <sup>(3)</sup> are provided in Table 3 below.

TABLE 3 - EXTRACT FOR MBIE TECHNICAL GUIDANCE (TABLE 3.1) INDEX CRITERIA FOR FOUNDATION TECHNICAL CATEGORIES

Foundation Technical Category	Future land performance expectations from liquefaction	Nominal SLS land settlement	Nominal ULS land settlement	Nominal Lateral Stretch
TC1	Liquefaction damage is unlikely in a future large earthquake	0-15mm	0-25mm	Generally not expected
TC2	Liquefaction damage is possible in a future large earthquake	0-50mm	0-100mm	<50mm

The ground conditions shall be established by a geotechnical investigation compliant with local Territorial requirements and MBIE technical guidance for a TC2 site.

The floor system needs to comply with the design rules developed for TC2 floor systems as summarised in the MBIE technical document. The design cases being:

- 1 An assumed loss of support of 2m along the edge of the flooring system (refer to the Ministry of Business, Innovation and Employment (MBIE) guidelines section 15.4, page 15.46 for additional details). The design load case shall be  $G+0.3Q$  and floor plate curvature shall be less than 1 in 200mm.
- 2 An assumed loss of 4m in the interior of the floor system. The design load case being  $G+0.3Q$  and the calculated deflection should be less than 1 in 400 (5mm hog or sag in centre of 4m length).

**Note** the purpose of this design methodology is to ensure that the floor is sufficiently stiff and strong. It is not expected that the ground will actually pull away from the foundation for 2-4m lengths.

Given the approximate nature of the analysis, a simple fixed ended cantilever is typically assumed for the 2m loss of edge support. For the 4m internal loss a support, either a fixed-fixed support condition is assumed for the interior of the slab, or a fixed-pin support condition where one end of the 4m section coincides with the perimeter edge beam.

Reinforcement shall be provided to support the design actions. Design shall be in accordance with NZS3101. One advantage of using the 750mm grid is that the trigger for requiring shear reinforcement occurs when the design shear force exceeds  $\phi V_c$ , as allowed by 9.3.9.4.13(b) of NZS3101 (incl amendment 3). Often the design actions can be resisted by the concrete contribution to the shear strength, meaning that shear reinforcement is not required. Note in other flooring systems with rib spacing's greater than 750mm, the trigger is  $0.5\phi V_c$ , which often necessitates the

use of stirrups or steel fibres to provide the required shear reinforcement.

Reinforcement to resist moments causing tension in the slab can be resisted either by mesh (Class E) or additional reinforcement placed in the top of the ribs.

The design should consider whether liquefaction is likely to enter the voids formed by the X-Pod<sup>®</sup>s. In sites where the geotechnical advice is that surface expression of liquefaction is unlikely, no specific precautions are required. The brief for the geotechnical engineering report should include commentary on this. Where expression is likely, a geofabric or geogrid reinforced granular layer shall be provided below the X-Pod<sup>®</sup>s to minimise the potential for liquefaction to enter the void created by the X-Pod<sup>®</sup>. Refer section 2.6 for commentary.

The above design methodology is associated with assessing the performance during an earthquake causing liquefaction. In addition the performance under gravity actions shall be assessed as outlined in design case 1 (section 4.2).

#### 4.3 DESIGN CASE 3 - DESIGN FOR EXPANSIVE SOIL SITE

The RibRaft<sup>®</sup> X-Pod<sup>®</sup> 215/750 pods are recommended for expansive soil sites. Geotechnical investigation shall determine the geotechnical conditions prevalent at the site and categorise the site class as A to E in terms of AS2870.

BRANZ<sup>®</sup> have reviewed the design methodology described in Appendix F of AS2870 and consider it appropriate for use in NZ. The method involves determining the idealised mound shapes associated with either central heave (the soil around the building perimeter drying

and shrinking) or edge heave where the soil outside the perimeter is wet relative to the interior. Both potential situations need to be considered as research<sup>(9)</sup> has demonstrated that seasonal variation can cause the development of both heave scenarios. The edge heave scenario however, often governs the design.

The design process involves determining a foundation system which is considered sufficiently stiff and strong for the expected ground movements. The suggested maximum allowable settlements being dictated by the cladding system used. Often the geotechnical reports provides design guidance.

The ground movements are characterised by the expected surface movement which is a function of the depth of suction change (often the depth of the water table), the suction change and the instability index (the percent, vertical strain change per unit change in suction).

The above design methodology is associated with assessing the performance due to ground movement caused by expansive soils. In addition the performance under gravity actions shall be assessed as outlined in Design Case 1.



## 5 R VALUES

The insulation performance of a building element is measured by the “R-Value”. The schedule method is the simplest method to achieve compliance with Clause H1 of the Building Code. Using this method the minimum R-Values required for floors are R1.3 for light timber frame construction, and typically R1.5 for masonry construction. R values of R1.3 can be used for masonry construction if glazing with greater insulation is used (refer NZBC, Clause H1). If in-floor heating is used the minimum required R-Value is increased to R1.9, and the resistance to thermal movement into the room must be one tenth of that to the outside environment.

The RibRaft® XPod system was designed to be a superior structural solutions with the potential to use recycled plastics while eliminating the use of polystyrene. In terms of its thermal characteristics it should be

considered to be similar (although slightly better) than a concrete slab on grade. The fourth edition of H1 (amendment 3, January 2017) states that “Concrete slab-on-ground floors are deemed to achieve a construction R-value of 1.3, unless a higher R-value is justified by calculation or physical testing.” RibRaft® X-Pod® is therefore a deemed to comply solution however in some instances designers may wish to determine the R value as part of the design process.

There are numerous methods for calculating R values for slabs on ground, with many of the processes giving quite different R values. NZBC clause H1 prescribes that an “Acceptable methods for determining the thermal resistance (R-values) of building elements are contained in NZS 4214.”

If the R value calculation is required to demonstrate compliance with the Building Code, then the NZS4214 methodology is probably the best

alternative due to its reference in H1. This method also appears to have been used to calibrate the minimum R-values stipulated in H1. This simplistic methodology for demonstrating compliance was probably utilized as the energy loss through a concrete slab on ground represent only about 10% of the losses in a NZBC compliant building. R values calculated using NZS4214 are provided in Table 5. These are provided for the 215/750 pod with standard and ThermoX DPM.

More technically robust calculation methodologies exist and where the R values are important, use can be made of the BRANZ Home Insulation Guide<sup>(10)</sup> which is based upon two dimensional thermal modeling and tends to calculate lower R values than the NZS4214 method. Table 6 has been derived from the 5th Edition of the Home insulation Guide for a slab on grade.

**TABLE 5 - R VALUES FOR SLABS ON GRADE WITH 90MM WALL FRAMING USING NZS4214**

R-Value m <sup>2</sup> °C/W	Floor Area To Perimeter Ratio m <sup>2</sup> /m										
	1.00	1.25	1.50	1.75	2.00	2.25	2.5	2.75	3.0	3.5	4.00
Standard DPM	1.0*	1.12*	1.24*	1.36	1.47	1.58	1.69	1.79	1.90	2.1	2.3
ThermoX DPM	1.14*	1.29*	1.42	1.55	1.67	1.79	1.91	2.02	2.13	2.34	2.55

\*Deemed to be R value of R1.3 by NZBC, H1 for Building Code Compliance.

**TABLE 6 - R VALUES FOR SLABS ON GRADE WITH 90MM WALL FRAMING USING BRANZ METHODOLOGY (OTHER OPTIONS REFER TO BRANZ HOME INSULATION GUIDE)**

R-Value m <sup>2</sup> °C/W	Floor Area To Perimeter Ratio m <sup>2</sup> /m										
	1.00	1.25	1.50	1.75	2.00	2.25	2.5	2.75	3.0	3.5	4.00
Standard DPM	0.69*	0.78*	0.88*	0.97*	1.06*	1.16*	1.2*	1.24*	1.43	1.61	1.8
R10 edge insulation	1.0*	1.17*	1.31	1.45	1.59	1.73	1.9	2.0	2.15	2.42	2.7

\*Deemed to be R value of R1.3 by NZBC, H1 for Building Code Compliance.

The use of ThermoX DPM reflective DPM increase the R value for any situation in Table 6 by R0.1.

## 6 PLUMBING

Various Territorial Authorities have their own preferences for plumbing details so always check with the local council.

Two options exist for running plumbing:

- The pipes are installed in the ground below the slab and then rise up through the slab at the desired location within the building, referred to as “below slab installation”. This is the preferred option in most situations.
- The pipes run within the plane of the X-Pod® flooring system, referred to as “in floor installation”.

### 6.1 BELOW SLAB PLUMBING INSTALLATION METHODOLOGY

This option is applicable for most situations but should not be used on liquefaction sites for which lateral spread is expected. In most situations this is the norm and most cost effective solution.

For this option, pipes shall be conveyed underground to their plan location then brought up through the X-Pod® and the concrete floor slab. Services shall not be placed within any concrete except to cross that section of concrete i.e. services shall not run along ribs or edge beams. In accordance with AS/NZS3500.4:2015 pipes penetrating through concrete shall be:

- Installed at right angles to the slab surface
- Lagged with an impermeable material for the full depth of the concrete penetration
- Lagging must be at least 6mm thick

Any services crossing ribs or the edge beam horizontally shall be placed only within the middle third of the member. At no stage shall any of the reinforcement bars be relocated or cut to allow for the services (it is acceptable, however to cut the mesh). In some instances this will dictate the location of the ribs.

The X-Pod® ADJ spacers can be used to trim around plumbing penetrations if required.

Below slab installation showing lagging of pipes

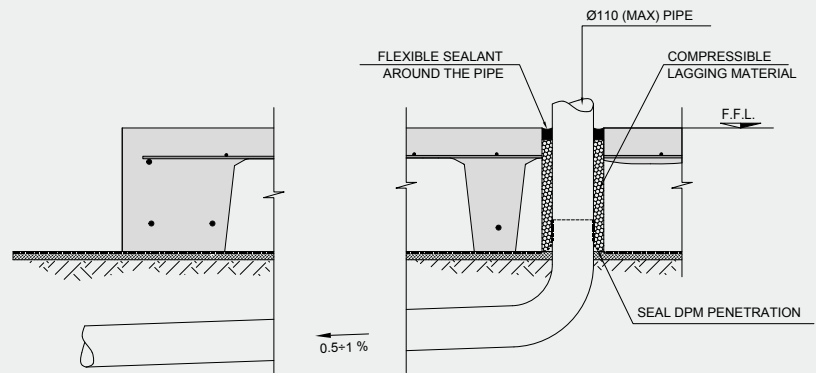

Details where large diameter pipe required through perimeter beam

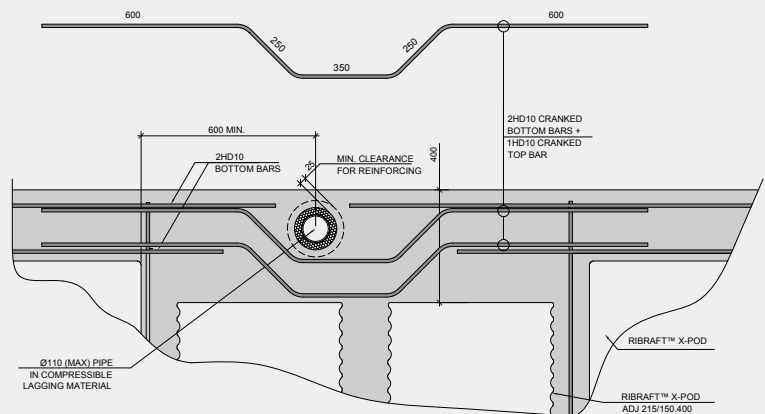

Use of X-Pod® ADJ pods to create zone for pipes to penetrate slab

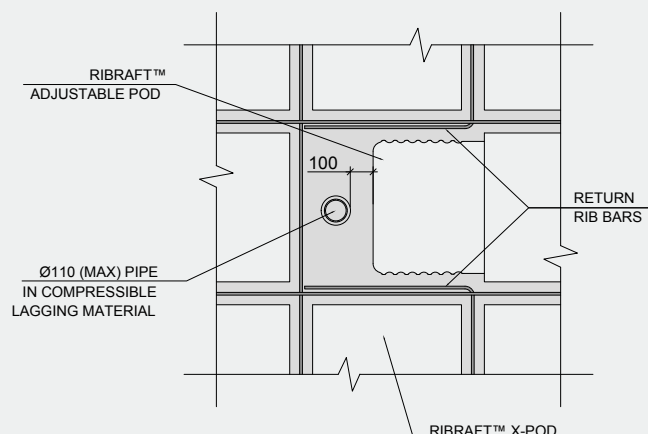

Illustrations: © Cresco.co.nz

**6.2 IN FLOOR PLUMBING INSTALLATION METHODOLOGY**

This is the preferred methodology for site where liquefaction and lateral spread are expected as it provides enhanced protection for the pipes compared to the below slab methodology. However it can be used for all ground conditions.

Pipes services can be run within the plane of the X-Pod®s either exiting out of the side of the perimeter ring beam or going underground near the edge beam. Pipes shall be laid at a fall to comply with NZBC G13/AS1. For pipes up to 65mm diameter the minimum gradient is typically 1 in 40, while for 100mm pipes its 1 in 60, however greater falls may be required dependent upon the required number of

discharge units. Table 7 provides distances from the edge of the slab to pipe surface penetration to achieve minimum pipe gradients. Where gradients cannot be achieved, then services will require to be run under the slab.

Pipes shall be located to pass perpendicular to the ribs and beams and shall not be laid along the length of ribs or beams. X-Pod®s can be cut as required to achieve the required fall and position. The adjustable X-Pod® can be used to create beams to run services through. Pipes shall be laid to ensure 15mm concrete cover between pipe and reinforcement in the perimeter beam. All pipes in contact with concrete shall be lagged with an impermeable material of at least 6mm thickness.

**TABLE 7 - MAXIMUM DISTANCE FROM EXTERIOR TO ENTRANCE POINT OF PLUMBING PIPES**

PIPE DIAMETER (ID)MM	GRADIENT	MAXIMUM DISTANCE TO EDGE WITH 215MM THICK POD
40	1 in 40	3400
50	1 in 40	3000
65	1 in 40	2400
100	1 in 60	1200

Typical details are shown below.

**Figure 9**  
In slab installation pipes cut through rib walls

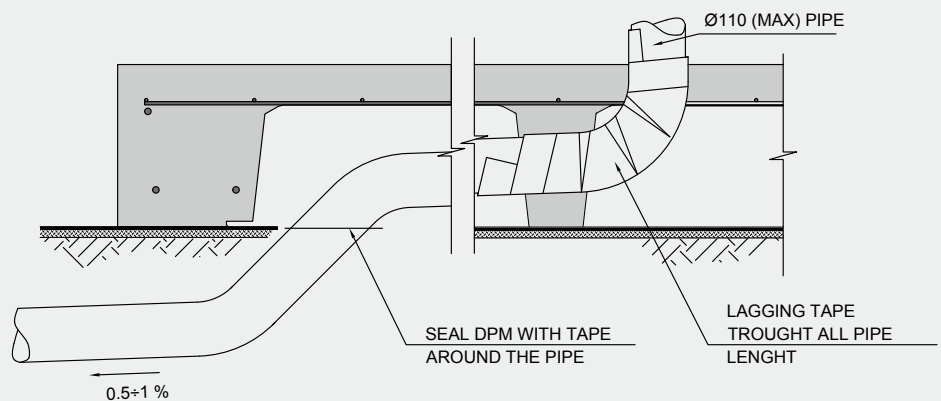
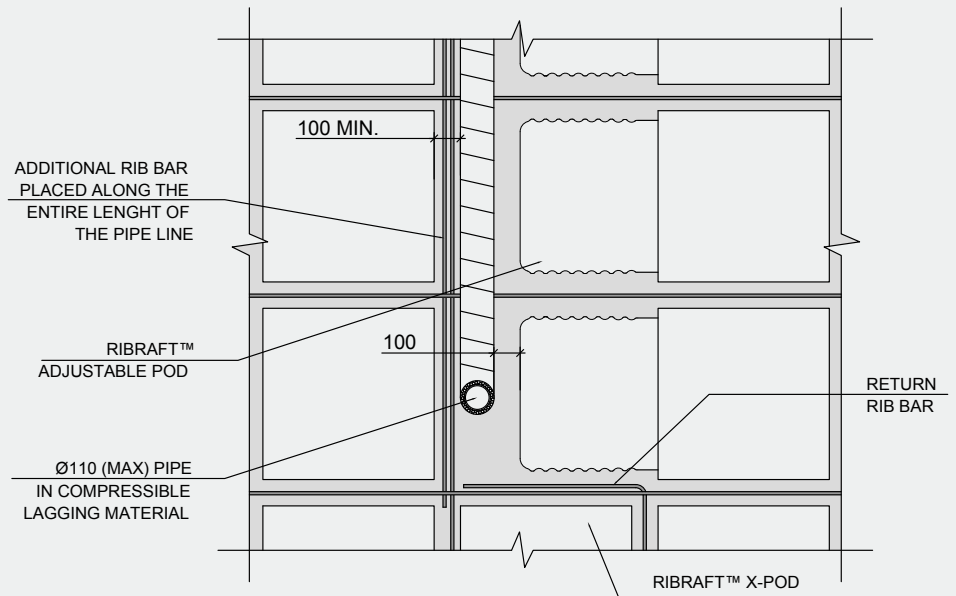
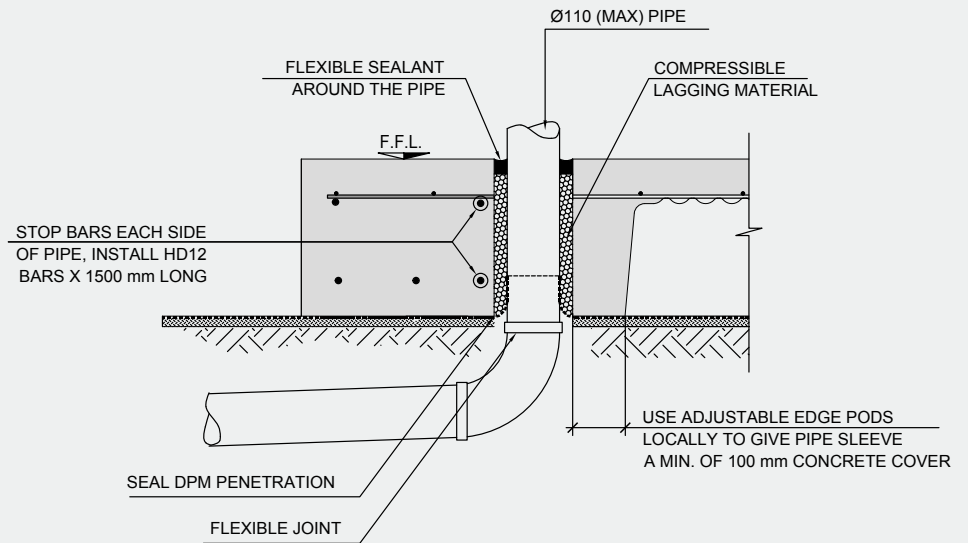

Illustration: © Cresco.co.nz

Use of X-Pod® ADJ pods to create zone for pipes to run without compromising Ribs



Typical drop down detail for sewer line to prevent it being visible at exterior of slab



### 6.3 RECESSES FOR SHOWERS

The following figures provide typical details for recesses and large penetrations

#### Shower recess distant from slab edge

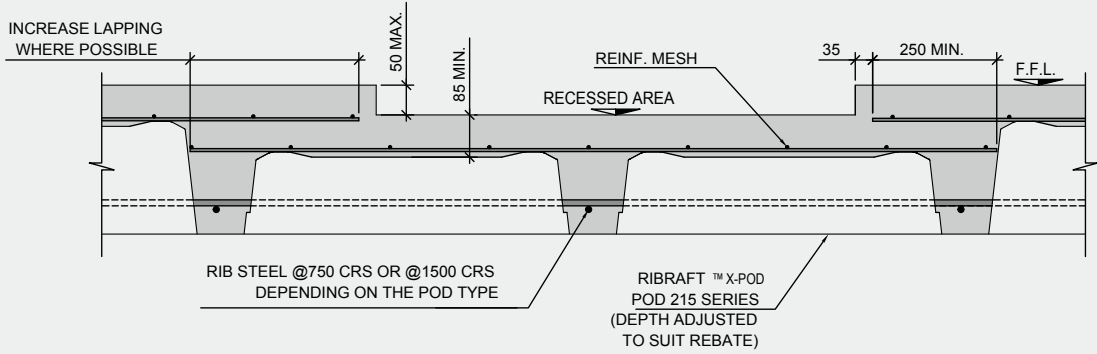

#### Shower recess close to slab edge

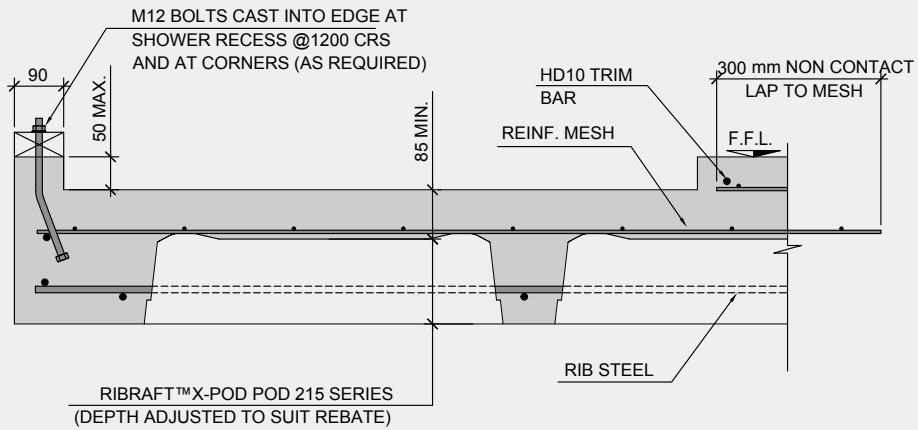

#### Large penetration through slab

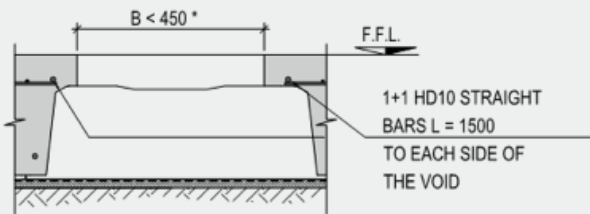

(\* IF B > 450 mm PLACE 2 HD10 CRACK CONTROL BARS @ 200 L = 2000 AT EACH CORNER OF THE PENETRATION

#### How to adjust depth of pod to suit rebate

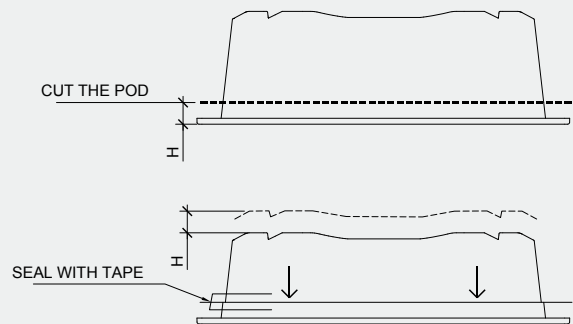



## 7 FINISH FLOOR LEVEL ABOVE GROUND

The finished floor level shall ensure that the height above ground level satisfies the greater requirements of:

- E1/AS1, refer section 2 in particular
- E2/AS1, refer section 9.1 in particular
- Any local flood management clearance criteria



## 8 DESIGN DOCUMENTATION

Designers shall provide drawings, calculations, PS1, Memorandum from a LBP, and a schedule of required inspections for consent applications.

Drawings shall ensure that the following notes are provided in addition to the engineers standard notes:

- RibRaft® X-Pod®, and keystones shall be provided by Firth Industries.
- All concrete shall be either 20MPa or 25MPa dependent upon NZS3604 durability zone. Firth mix code IP2519X or IP2019X shall be used, no substitution shall be allowed.
- All Reinforcing bars shall be Grade 500E and comply with AS/NZS4671.
- All mesh shall be Grade 500E preferably supplied by Fletcher Reinforcing. Class L mesh can be used for design solutions were liquefaction or expansive clays are not a consideration.
- Where specified Firth HotEdge® shall be installed in accordance with manufactures instructions and supplied by Firth industries.
- Construction shall be by installers familiar with residential floor constructions.

## 9 REFERENCES

- 1 Foundation Engineering Handbook, Winterkorn, Fang
- 2 Analyses of Multi-edge footings resisted on loose and dense sand, Davarci, Ornek, Turedi
- 3 Guidance on Repairing and rebuilding houses affected by the Canterbury Earthquake, MBIE
- 4 AS2870 Residential Slabs and Footing Construction.
- 5 NZS3101 - Concrete Structures Standard
- 6 Walsh, 1978, Technical Research Paper - The analysis of stiffened rafts on expansive clays
- 7 Mitchel,1984, A simple method of design of shallow foundations on expansive soil
- 8 BRANZ Study report 120- Soil expansivity in the Auckland Region
- 9 Li, University of South Australia, 1996, Analysis and Performance of Footings on expansive Soils
- 10 Branz, 2014, Home Insulation Guide Fifth Edition
- 11 Ishihara, K., 1985. "Stability of natural soil deposits during earthquakes". International Conference on Soil Mechanics and Foundation Engineering, San Francisco: 321-376
- 12 Van Ballegooy, S. et al., 2014. "Assessment of liquefaction-induced land damage for residential Christchurch". Earthquake Spectra, 30(1): 31-35

