

① 220mm FIRTH RIBRAFT POLYPOD  
90mm WALL FRAME HOTEDGE EXTRA  
FIRTH RAFTMIX 20 OR 25MPa

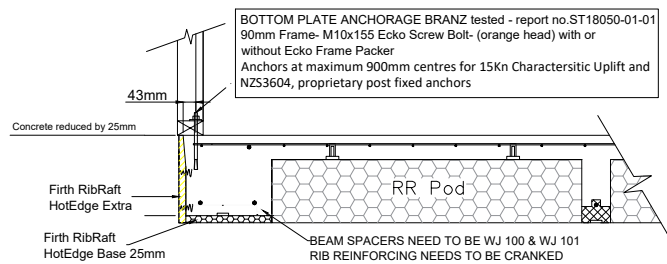

② 220mm FIRTH RIBRAFT POLYPOD  
90mm WALL FRAME HOTEDGE EXTRA & HOTEDGE BASE  
FIRTH RAFTMIX 20 OR 25MPa

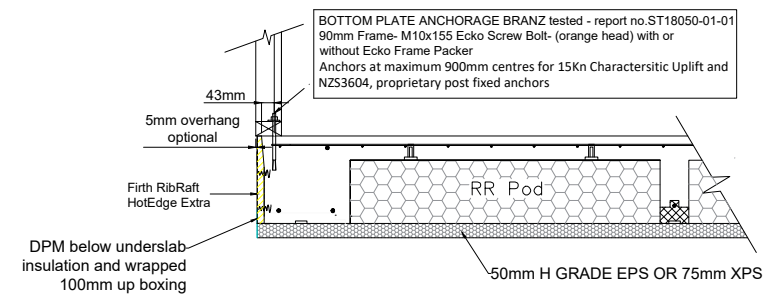

③ 220mm FIRTH RIBRAFT POLYPOD  
90mm WALL FRAME HOTEDGE EXTRA & UNDERSLAB INSULATION  
FIRTH RAFTMIX 20 OR 25MPa

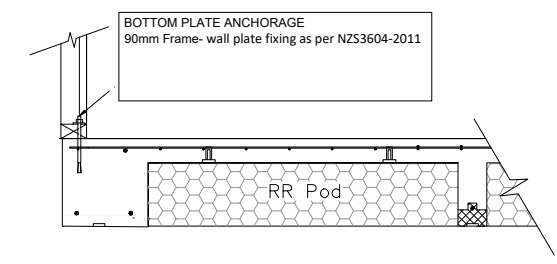

④ 220mm FIRTH RIBRAFT POLYPOD  
90mm WALL FRAME  
FIRTH RAFTMIX 20 OR 25MPa

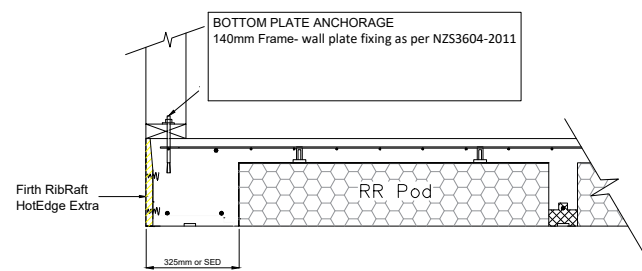

⑤ 220mm FIRTH RIBRAFT POLYPOD  
140mm WALL FRAME HOTEDGE EXTRA  
FIRTH RAFTMIX 20 OR 25MPa

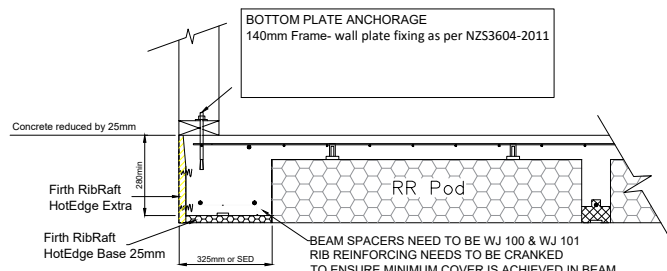

⑥ 220mm FIRTH RIBRAFT POLYPOD  
140mm WALL FRAME HOTEDGE EXTRA & HOTEDGE BASE  
FIRTH RAFTMIX 20 OR 25MPa

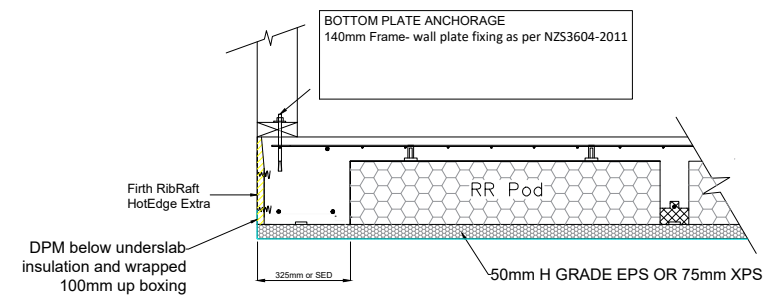

⑦ 220mm FIRTH RIBRAFT POLYPOD  
140mm WALL FRAME HOTEDGE EXTRA & UNDERSLAB INSULATION  
FIRTH RAFTMIX 20 OR 25MPa

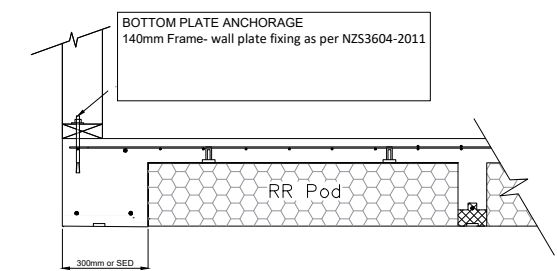

⑧ 220mm FIRTH RIBRAFT POLYPOD  
90mm WALL FRAME  
FIRTH RAFTMIX 20 OR 25MPa

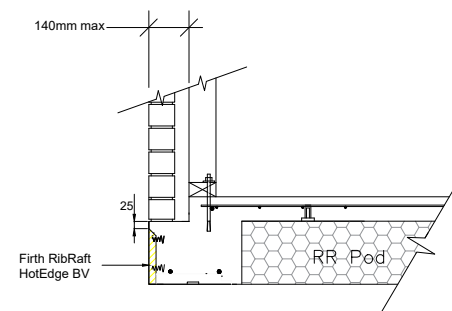

⑨ 220mm FIRTH RIBRAFT POLYPOD  
BRICK VENEER HOTEDGE  
FIRTH RAFTMIX 20 OR 25MPa

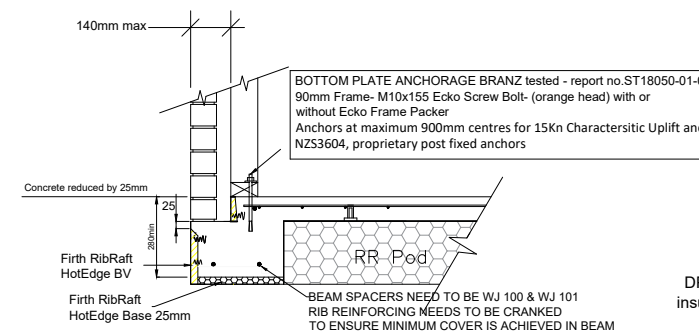

⑩ 220mm FIRTH RIBRAFT POLYPOD  
BRICK VENEER HOTEDGE & HOTEDGE BASE  
FIRTH RAFTMIX 20 OR 25MPa

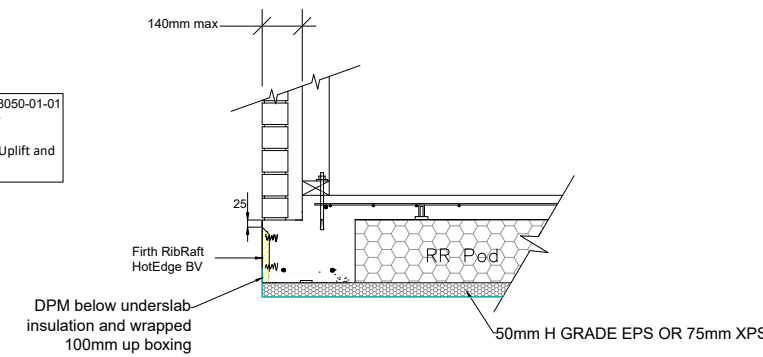

⑪ 220mm FIRTH RIBRAFT POLYPOD  
BRICK VENEER HOTEDGE & UNDERSLAB INSULATION  
FIRTH RAFTMIX 20 OR 25MPa

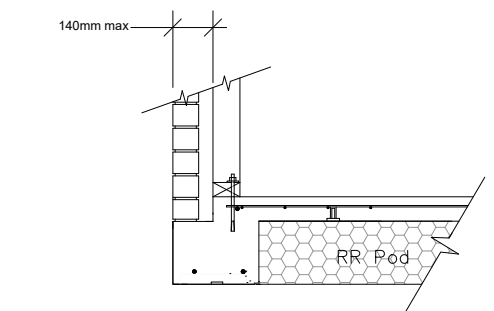

⑫ 220mm FIRTH RIBRAFT POLYPOD  
BRICK VENEER  
FIRTH RAFTMIX 20 OR 25MPa



SHEET TITLE: RIBRAFT 220mm Pod  
HOTEDGE DETAILS  
TIMBER FRAME  
CONSTRUCTION

DESIGNED: DRAWN:  
CHECKED: CAD DWG.:  
SCALES: DATE July 2024  
DWG NO.