



+Ribraft[®] HotEdge[®]



RIBRAFT[®]
HOTEDGE[®]

THIS MANUAL HAS BEEN DEVELOPED FOR FIRTH RIBRAFT®HOTEDGE®. RIBRAFT® HOTEDGE® IS A FULLY INTEGRATED SLAB EDGE INSULATION SYSTEM, DESIGNED SPECIFICALLY FOR FIRTH RIBRAFT® FLOORS USING FIRTH RAFTMIX® CONCRETE.

SITE/EARTHWORKS

RibRaft® HotEdge® does not affect bearing pressures or foundation requirements, therefore earthworks, cut, fill and bearing checks to remain as per Firth RibRaft® Technical Manual or specific engineering design.

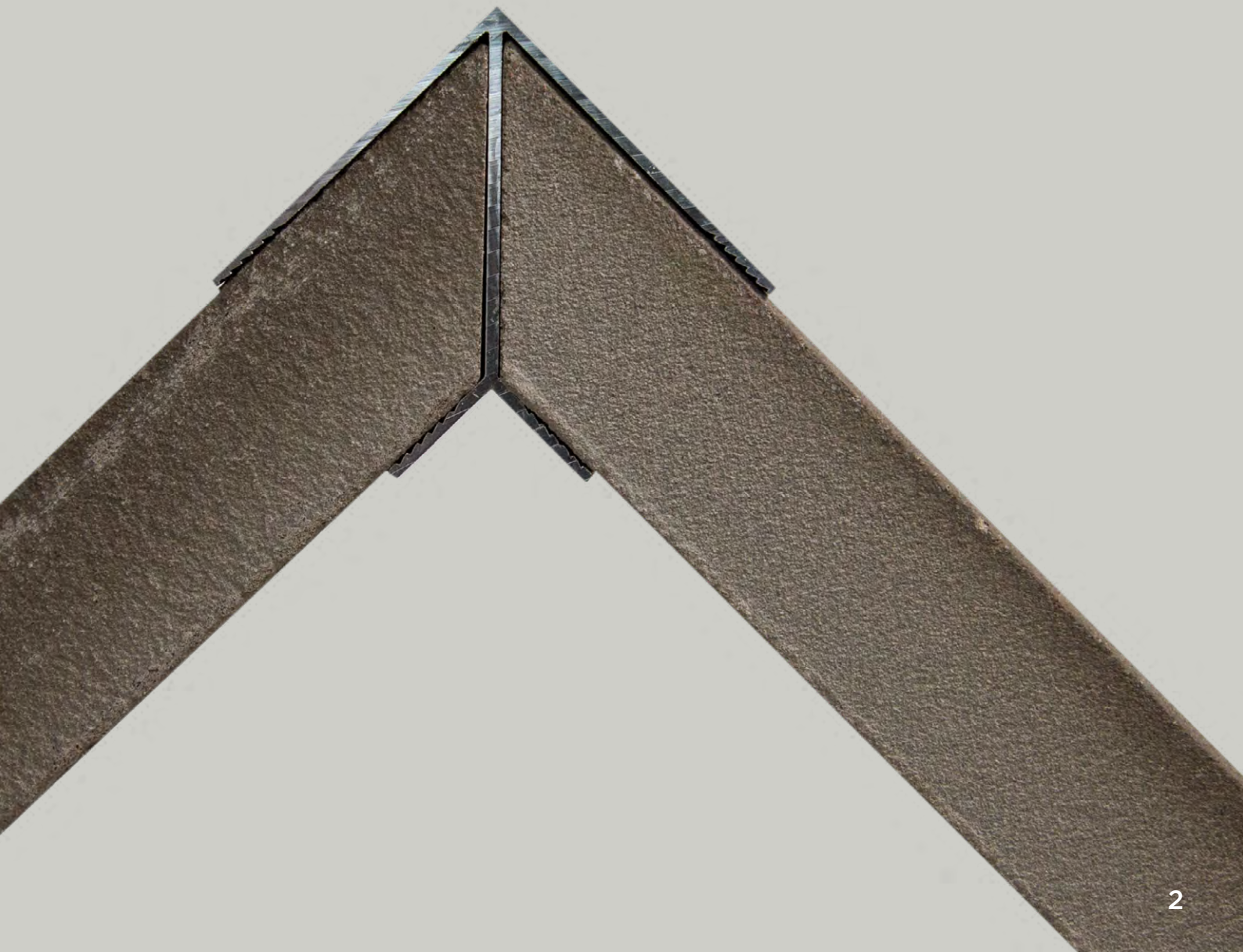

FORMWORK SETUP

Perimeter shutters shall be set to profiles or string lines with top edge at finished floor level (FFL). Setting level of shutters must allow for variation across prepared base and final hand screed of sand blinding layer (to +/- 5mm). Shutters shall be adequately braced to ensure minimal movement occurs under full load of wet vibrated concrete and construction loadings. Special care must be taken to ensure joints between adjacent shutters have a minimum step out of straightness (see **Figure A**) to reduce chances of grout loss between shutter and HotEdge®.

Edge beam details that include rebate former for flush aluminium joinery, brick veneer or garage door rebate, shall be secured to shutters once HotEdge® have been affixed to shutters.



HOTEDGE® SETUP

DANDAM FOAM TAPE

DanDam Foam tape should be adhered to top and bottom edges of HotEdge® to reduce chances of concrete grout loss between form and HotEdge® sheet (**Figure B**). Tape will adhere to a damp surface, however if HotEdge® is wet, dry with rag and lay face up for surface to dry.



TORNADO SCREW

Fasten Tornado screws to HotEdge® using battery drill and #3 Phillips head driver, screw connectors 20-25mm depth into foam sheet. Phillips head driver will lose traction with screw windings ensuring screw cannot damage plaster on opposite face, alternatively reduce clutch torque setting to low level. Tornado screws are to be at 300mm crs staggered top and bottom, 25-40mm from plastered top and bottom edges (bulls eye target locators are printed on inside face of HotEdge®), refer **Figure C**.





HOTEDGE® INSTALLATION

NON-REBATE, LIGHT CLAD EDGE BEAM DETAIL

Use chalk line to mark boxing 25mm below finished floor level (FFL) for reference datum to align HotEdge® to. Starting from an external corner, fit mitre cut HotEdge® end to aluminium profile using flexible sealant (i.e. MS or Polyurethane). Refer **Figure D**.

Secure each HotEdge® section to shutters with 19mm polypropylene strapping and tension by hand with plastic buckles, refer **Figure E**.

Strap HotEdge® to boxing at maximum 1.5m centres, closer spacing may be needed if gap forms between DanDam foam tape and shutters (refer **Figure F**).

Fitting 25mm timber spacer block (**Figure G**) in between HotEdge® top edge and strapping will reduce vertical movement of HotEdge® relative to shutter top edge.



BRICK REBATE EDGE BEAM DETAIL

Use chalk line to mark boxing 25mm below lower edge of rebate form position for reference datum to align HotEdge® insulation forms to. Starting from an external corner, fit mitre cut HotEdge® board to aluminium profile using flexible sealant (i.e. MS or Polyurethane), refer **Figure D**.

Secure HotEdge® to shutter by fixing strapping tape to shutter internal face with hand stapler, directly below lower edge of position rebate form is to be fixed. Pull free end of strapping under shutter, returning up outside face of shutter and fix to shutter frame with hand stapler.

Working away from corner, join HotEdge® lengths at shiplap joint (**Figure H**) and bond with sealant. Do not attempt to cut and reform new shiplap joint, rather cut required length at the next corner (mitre at external corner, butt joint at internal corner). If HotEdge® is to be fitted below garage door rebate or flush aluminium joinery rebate, width of HotEdge® may need to be reduced. Circular saw with masonry carborundum or fibre-cement board tungsten tipped blade (**Figure I**) can be used to rip strip from lower edge. Cut edge shall be painted with bituminous type waterproof membrane (i.e. Mulseal type product used to seal brick veneer rebate).

ALTERNATIVE FIXING

For applications where strapping HotEdge® to form shutters is not practical, direct fixing from formwork to HotEdge® should be considered. At maximum 1.5 crs, fix HotEdge® profile to exterior form via 12 gauge tex screws through HotEdge® and into timber/plywood backer, refer (**Figure J**).

This option provides rigid connection to formwork, however drilling through shutters, plus repair of penetration in HotEdge® profile may not be suitable for some installers/customers.

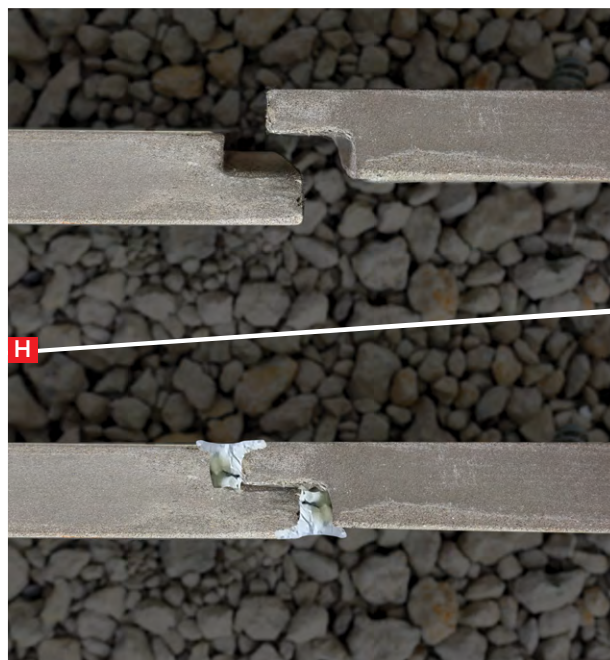
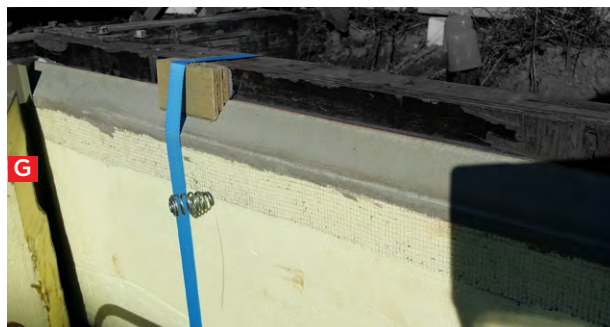

CONCRETE INSTALLATION

HotEdge® thermal parameters have been based around use of Firth RaftMix® concrete (i.e. RP2019AW or other versions available). This mix is designed to have a suitable strength at a higher slump (target 120mm). The mix also incorporates additives to ensure concrete flows into place (with immersion type vibrator) around HotEdge® Tornado screws and over top edge of HotEdge® chamfer. Pumping concrete is typically the only method of delivering the fresh concrete to the work face. Other methods of delivery may be suitable however approval from Firth or project engineer is required.

- 1** It is generally preferable to start pour at the garage (allows a harder, flatter finish), and work away. Controlling the flow from the pump nozzle is crucial, and in no circumstances shall concrete pressure be directed directly between and under pods. If pods lift during pouring, the pour shall be stopped and concrete cleaned out.
 - 2** Follow behind pour face with immersion (spud) type vibrator to all concrete (beams, ribs and top slab). Adequate vibration is essential to ensure structural integrity and consolidation around reinforcing and HotEdge®.
 - 3** Care must be taken to avoid vibrator coming in contact with HotEdge®, to ensure damage or movement does not occur. If movement or damage to HotEdge® is noticed during pouring, pour shall be halted, concrete dugout and HotEdge® securely reinstated.
 - 4** Following vibration, normal concrete finishing techniques shall be carried out.
 - 5** If hot and/or windy conditions present during pouring/finishing, necessary steps must be taken as protection of concrete is essential to prevent plastic cracking. Protection measures include:
 - a. Aliphatic alcohol sprays
 - b. Water vapour misting over surface (i.e. from water blaster directed upward, and wind carrying mist over slab surface)
 - c. Positioning wind breaks
 - 6** Curing slab is crucial to ensure strength gain of concrete and protection from early age cracking. Suitable methods of curing include:
 - a. Water spraying/ponding
 - b. Curing membrane sprays
 - c. Polythene covering
 - 7** If environmental conditions forecast greater than 15 degrees variation of day time to overnight temperatures, then measures to protect slab from thermal shock shall be employed, these include:
 - a. Continuously running or spraying water over surface over night
 - b. Covering surface with fabric, plastic covers or polythene
- Shrinkage saw cutting of top slab is typically required, however specific shapes and sizes of floor plan may have no cuts or special requirements, refer project drawings for requirement or placement, or Firth RibRaft® Technical Manual.
- Forms shall not be struck on day of pour, and consideration should be given for leaving forms in place for 2-3 days following pour in very cold or shaded locations.

STRIPPING SHUTTERS

Prior to stripping, plastic strapping must be cut with utility knife. Shutters shall be gently pried from edge beams, ensuring MS sealant to top edge of HotEdge® pulls off shutter without causing damage or dislodgement to HotEdge® top edge.

FINISHING

Shiplap joints and other gaps shall be filled with MS or polyurethane type sealant. Damage or holes in HotEdge® exposed plaster face shall be patch repaired with HotEdge® TidyUp® repair product available from Firth. HotEdge® and 25mm concrete above shall be coated with 2 coats of high build acrylic paint. Firth RibRaft® HotEdge® is warranted against material or manufacturing defect or failure for 15 years from manufacture, in accordance with New Zealand Building Code B2, clause B2.3.1(b)(i).

CONSTRUCTION DETAIL

1

BRICK VENEER CONSTRUCTION DETAIL

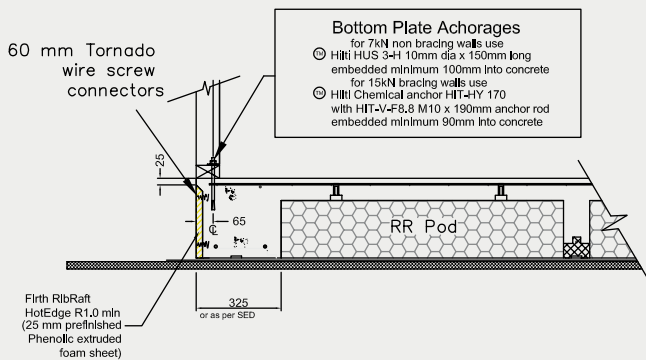

2

GARAGE DOOR STOP CONSTRUCTION DETAIL

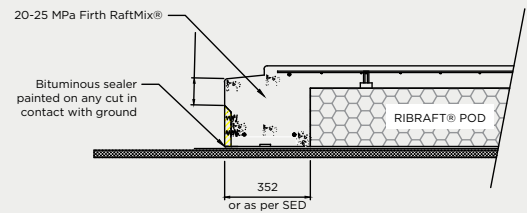

3

BRICK VENEER CONSTRUCTION DETAIL

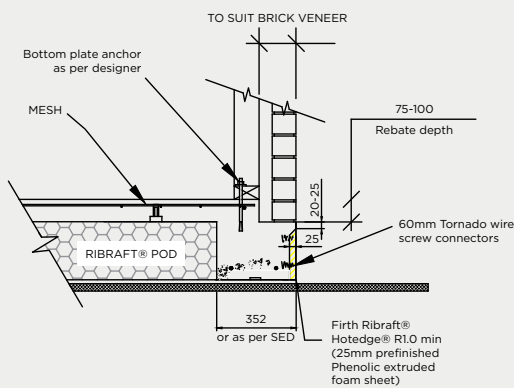

4

EXTERNAL CORNER CONSTRUCTION DETAIL

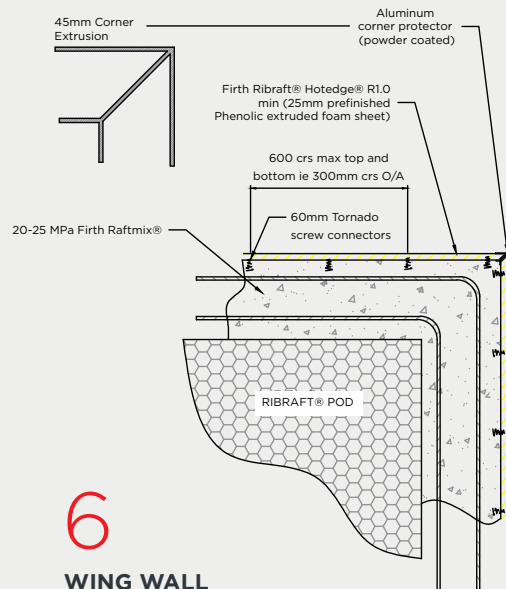

5

INTERNAL CORNER CONSTRUCTION DETAIL

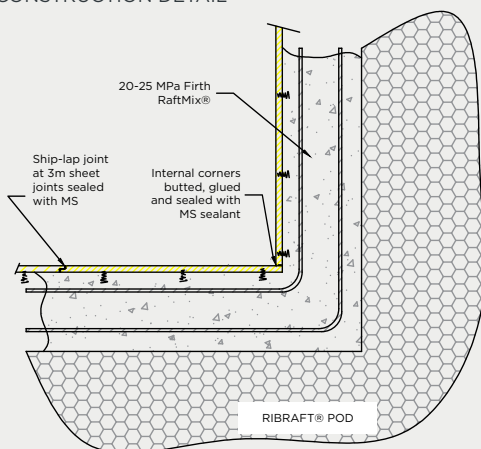

6

WING WALL CONSTRUCTION DETAIL

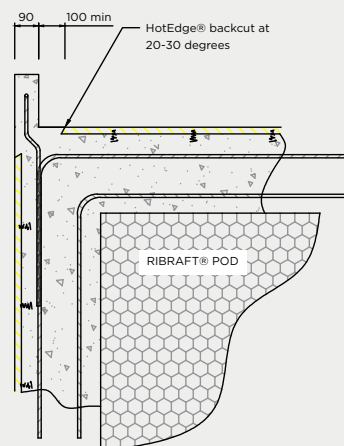

- RibRaft® HotEdge® is a pre mesh/plastered foundation edge insulation system. For optimum service life and insulation, 2 coats of acrylic paint should be maintained to all exposed surfaces.
- The insulation of HotEdge® has been 3D modeled by BRANZ and shown to provide minimum R1.0 to the full depth edge beam of Firth RibRaft® floors.
- For overall RibRaft® R value calculation with HotEdge®, refer BRANZ publication 'Home Insulation Guide', 5th Edition, 'R=1.0 to perimeter edge beam for waffle pod floor'.
- HotEdge® has been designed to be incorporated with RibRaft® CodeMark™ Technical Manual 2012. Inclusion inspecifically engineered floor systems must be checked and approved by CPeng, while using standard Firth RibRaft® details and materials/components (ie Firth 20/25 MPa RaftMix®).



(C) Firth Industries 2019. All rights reserved. Content in this document is protected under the Copyright Act 1994. No material may be reproduced in whole or in part without the written consent of the copyright holder.



0800 FIRTH 1 (347841)
FIRTH.CO.NZ

 **PRODUCTSPEC**
productspec.net

